

# Autonics

## ROTARY ENCODER(INCREMENTAL TYPE) E40S/E40H/E40HB/E80H SERIES

M A N U A L



Thank you very much for selecting Autonics products.  
For your safety, please read the following before using.

### Caution for your safety

- \*Please keep these instructions and review them before using this unit.
- \*Please observe the cautions that follow;
- Warning** Serious injury may result if instructions are not followed.
- Caution** Product may be damaged, or injury may result if instructions are not followed.
- \*The following is an explanation of the symbols used in the operation manual.
- Warning** Injury or danger may occur under special conditions.
- 1. In case of using this unit with machinery(Medical equipment, vehicle, train, airplane, combustion apparatus, entertainment processing equipment, conveyor, elevator or safety device etc.), it is required to install fail-safe device, or contact us for information on type required.**  
It may cause serious human injury or a fire, property.

### Caution

- 1. Do not drop water or oil on this unit.**  
It may cause damage or malfunction due to malfunction.
- 2. Please observe voltage rating.**  
It may shorten the life cycle or damage to the product.
- 3. Please check the polarity of power and wrong wiring.**  
It may result in damage to this unit.
- 4. Do not short circuit the load.**  
It may result in damage to this unit.

### Outline

This unit is very useful to control position and speed by converting revolution value of shaft into number of pulse as an optical incremental Encoder.

### Ordering information

Series	Shaft diameter	Pulse / 1Revolution	Output phase	Output	Power supply	Cable
E40S	6mm	5000	3	N	24	
E40S	6mm	*1, *2, *5, 10, *12, 15, 20, 23, 25, 30, 35, 40, 45, 50, 60, 75, 100, 120, 125, 150, 192, 200, 240, 250, 256, 300, 360, 400, 500, 512, 600, 800, 1000, 1024, 1200, 1500, 1800, 2000, 2048, 2500, 3000, 3600, 5000	2: A, B 3: A, B, Z 4: A, $\bar{A}$ , B, $\bar{B}$ 6: A, $\bar{A}$ , B, $\bar{B}$ , Z, $\bar{Z}$	T: Totem pole output N: NPN open collector output V: Voltage output L: Line Driver output	5: 5VDC $\pm$ 5% 24: 12~24VDC $\pm$ 5%	No mark: Normal type (*): Cable outgoing connector type
E40H	6mm					
E40HB	8mm, 10mm, 12mm					
E80H	30mm, 32mm	60, 100, 360, 500, 512, 1024, 3200	3: A, B, Z 6: A, $\bar{A}$ , B, $\bar{B}$ , Z, $\bar{Z}$			

\* \* \* indicates the standard specification of diameters.  
\* 1, 2, 5, 12 P/R are output A, B phase only. (But Line Driver output A,  $\bar{A}$ , B,  $\bar{B}$  phase)  
\* Cable length: 250mm

### Control output diagram

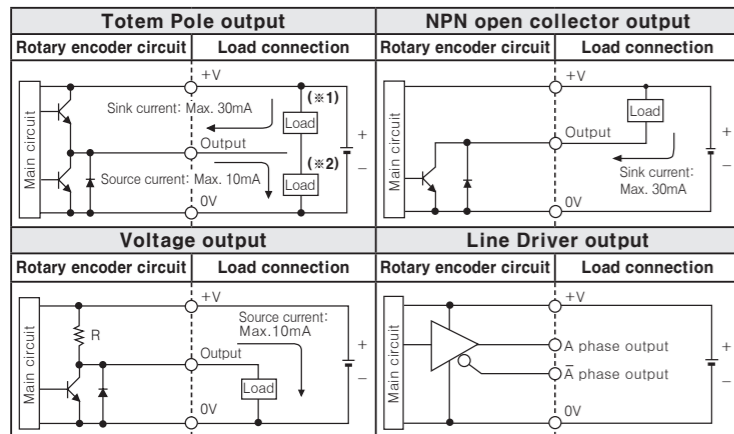

\* The output circuit of A, B, Z phase are the same. (Line Driver output is A,  $\bar{A}$ , B,  $\bar{B}$ , Z,  $\bar{Z}$  phase)  
\* Totem Pole output can be used for NPN open collector type(\*1) or voltage output type(\*2).  
\* The above specification are subject to change without notice.

### Specifications

Incremental Rotary encoder	$\phi$ 40mm Shaft type	$\phi$ 40mm Hollow shaft type	$\phi$ 40mm Hollow shaft Built-in type	$\phi$ 80mm Hollow shaft type
Model	E40S	E40H	E40HB	E80H
Totem Pole output	E40S-T	E40H-T	E40HB-T	E80H-T
NPN open collector output	E40S-N	E40H-N	E40HB-N	E80H-N
Voltage output	E40S-V	E40H-V	E40HB-V	E80H-V
Line Driver output	E40S-L	E40H-L	E40HB-L	E80H-L
Resolution(P/R)	*1, *2, *5, 10, *12, 15, 20, 23, 25, 30, 35, 40, 45, 50, 60, 75, 100, 120, 125, 150, 192, 200, 240, 250, 256, 300, 360, 400, 500, 512, 600, 800, 1000, 1024, 1200, 1500, 1800, 2000, 2048, 2500, 3000, 3600, 5000 (Not indicated type is available to customize)			60, 100, 360, 500, 512, 1024, 3200
Output phase(*1)	(*1) A, B, Z phase(Line Driver output: A, $\bar{A}$ , B, $\bar{B}$ , Z, $\bar{Z}$ phase)			
Phase difference between output	Output between A and B phase: $\frac{T}{4} \pm \frac{T}{8}$ (T = 1 cycle of A phase)			
Electrical specification				
Control output				
Totem Pole output	•Low $\Rightarrow$ Load current: Max. 30mA, Residual voltage: Max. 0.4VDC •High $\Rightarrow$ Load current: Max. 10mA, Output voltage(Power voltage 5VDC): Min. (Power voltage-2.0)VDC, Output voltage(Power voltage 12~24VDC): Min. (Power voltage-3.0)VDC			
NPN open collector output	Load current: Max. 30mA, Residual voltage: Max. 0.4VDC			
Voltage output	Load current: Max. 10mA, Residual voltage: Max. 0.4VDC			
Line Driver output	•Low $\Rightarrow$ Load current: Max. 20mA, Residual voltage: Max. 0.5VDC •High $\Rightarrow$ Load current: Max. -20mA, Output voltage(Power voltage 5VDC): Min. 2.5VDC, Output voltage(Power voltage 12~24VDC): Min. (Power voltage-3.0)VDC			
Response time(Rise/Fall)	Totem Pole output NPN open collector output Voltage output Line Driver output Max. 1 $\mu$ s (Cable length: 2m, I sink=20mA)			
Max. Response frequency	300kHz			
Power supply	•5VDC $\pm$ 5%(Ripple P-P: Max. 5%) •12~24VDC $\pm$ 5%(Ripple P-P: Max. 5%)			
Current consumption	Max. 80mA (disconnection of the load), Line Driver output: Max. 50mA(disconnection of the load)			
Insulation resistance	Min. 100M $\Omega$ (at 500VDC megger between all terminals and case)			
Dielectric strength	750VAC 50/60Hz for 1 minute(Between all terminals and case)			
Connection	Cable outgoing type, 250mm Cable outgoing connector type			
Mechanical specification				
Starting torque	Shaft Type: Max. 40gf-cm(0.004N-m), Hollow Type: Max. 50gf-cm(0.005N-m)		Max. 200gf-cm(0.02N-m)	
Moment of inertia	Max. 40g-cm <sup>2</sup> (4 $\times$ 10 <sup>-6</sup> kg-m <sup>2</sup> )		Max. 800g-cm <sup>2</sup> (8 $\times$ 10 <sup>-4</sup> kg-m <sup>2</sup> )	
Shaft loading	Radial: 2kgf, Thrust: 1kgf		Radial: 5kgf, Thrust: 2.5kgf	
Max. allowable revolution(*2)	5,000rpm		3,600rpm	
Vibration	1.5mm amplitude at frequency of 10~55Hz (for 1 min.) in each X, Y, Z direction for 2 hours			
Shock	Max. 50G		Max. 75G	
Environment	Ambient temperature: -10 ~ 70°C, Storage: -25 ~ 85°C Ambient humidity: 35 ~ 85% RH, Storage: 35 ~ 90% RH			
Protection	IP50(IEC Standards)			
Cable	$\phi$ 5mm, 5P, Length: 2m, Shield cable(Line Driver output: $\phi$ 5mm, 8P) (AWG 24, Core wire diameter: 0.08mm, No. of core wire: 40, Insulator out diameter: $\phi$ 1mm)			
Accessory	$\phi$ 6mm coupling(Standard), $\phi$ 8mm coupling(Option)		Bracket	
Approval	CE (Except for Line Driver output)			
Unit weight	Approx. 120g		Approx. 560g	

\* 1: 1, 2, 5, 12 P/R are output A, B phase only. (But Line Driver output: A,  $\bar{A}$ , B,  $\bar{B}$  phase)  
\* 2: Max. allowable revolution  $\geq$  Max. response revolution [Max. response revolution(rpm) =  $\frac{\text{Max. response frequency} \times 60 \text{ sec.}}{\text{Resolution}}$ ] Please select the resolution to make lower max. revolution than max. allowable revolution.  
\* Environment resistance is rated at no freezing or condensation.

### Dimensions

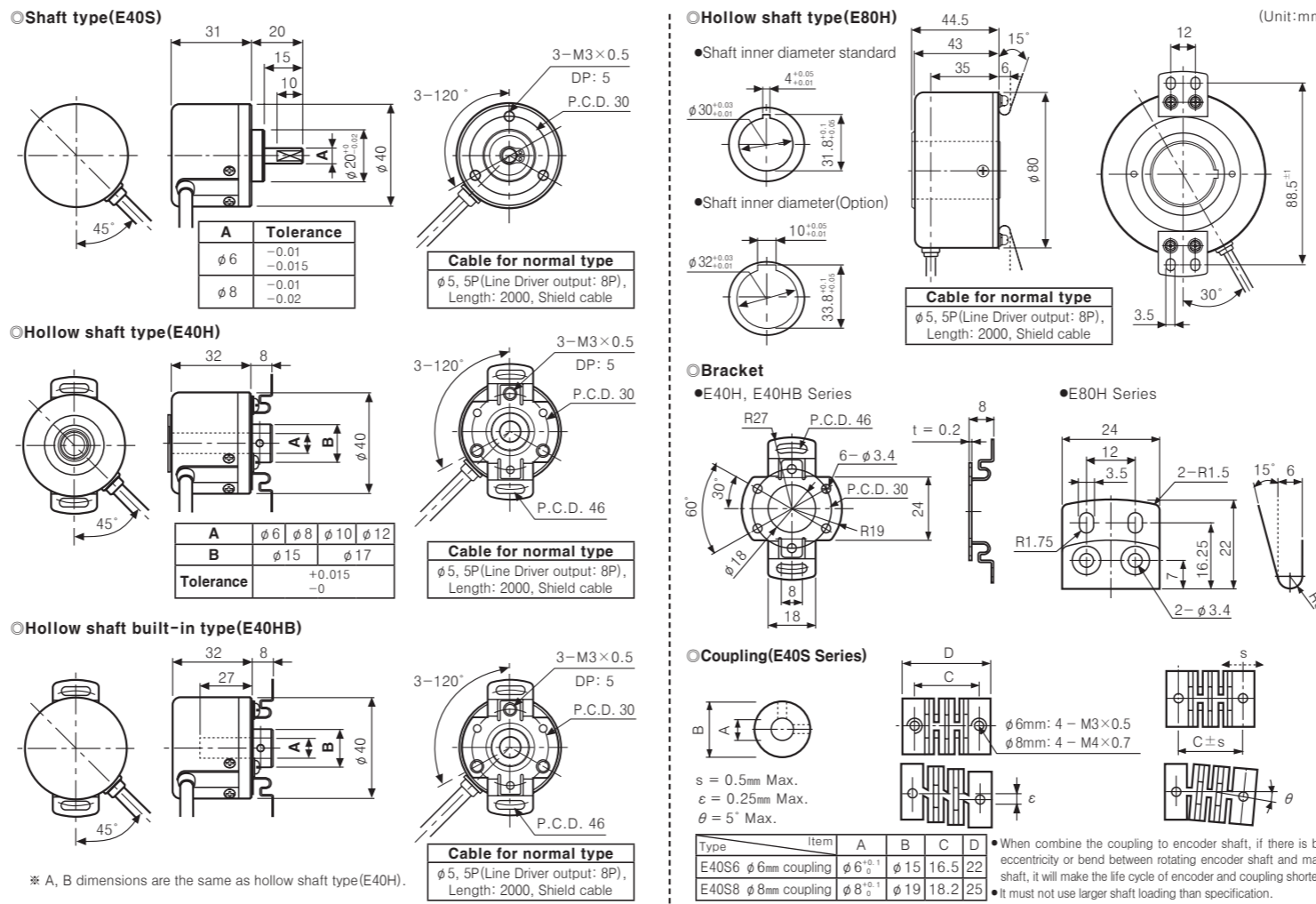

### Connections

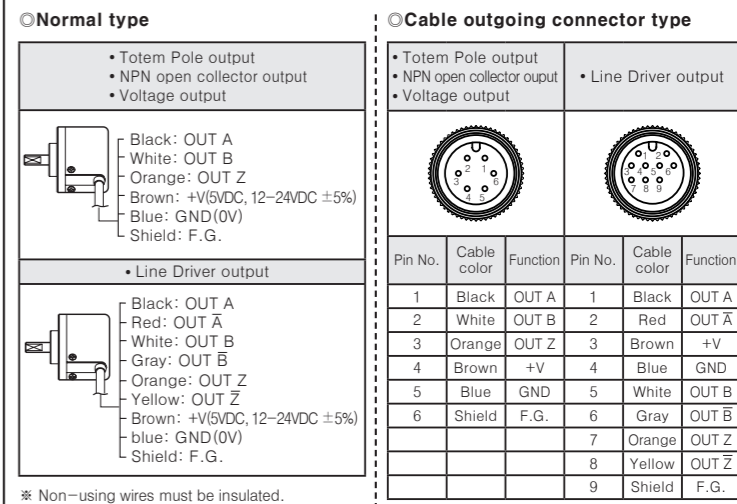

\* Non-using wires must be insulated.  
\* The shield cable and metal case of encoder must be grounded(F.G.).

### Output waveform

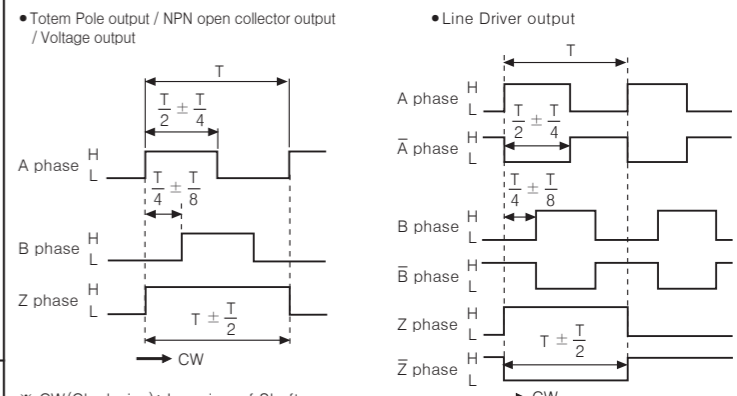

\* CW(Clockwise): In a view of Shaft.

### Caution for using

- 1. Installation**
    - This unit is consisted of precision components. Therefore please treat this product carefully.
    - When you install this unit, if eccentricity and deflection angle are larger, it may shorten the life cycle of this unit.
  - 2. Environment**
    - Please do not use this unit with below environment, it results in malfunction.
    - Place where this unit or component may be damaged by strong vibration or impact.
    - Place where there are lots of flammable or corrosive gases.
    - Place where strong magnet field or electric noise are occurred.
    - Place where there is beyond of rating temperature or humidity
    - Place where strong acids or alkali near by.
    - Place where there is the direct ray of the sun.
  - 3. Vibration and Impact**
    - When the strong impact loads on this unit, the error pulse may occur as if the slit is revolving.
    - Therefore please fix bracket firmly when mount this unit, because Rotary encoder with high resolution can be easily affected by impact.
  - 4. Wire connection**
    - Do not apply a tensile strength in excess of 30N to the cable.
    - When a high voltage or power line pass near by the encoder cable, be sure to wire the encoder cable in separated conduit to prevent malfunction.
    - When extend the cable, please use it after checking the cable and response frequency due to increment of residual voltage or distortion of waveform can be easily occurred. (Preferable shortest distance for operating)
    - Shield wire must be connected to F.G. terminal.
- \* It may cause malfunction if above instructions are not followed.

### Major products

- Proximity sensors
- Area sensors
- Photoelectric sensors
- Fiber optic sensors
- Door/Door side sensors
- Counters
- Timers
- Display units
- Panel meters
- Pressure sensors
- Rotary encoders
- Power controllers
- Sensor controllers
- Graphic/Logic panels
- Temperature controllers
- Tachometer/Pulse(Rate) meters
- Temperature/Humidity transducers
- Switching power supplies
- Stepping motors/drivers/motion controllers
- Field network devices
- Laser marking system(CO<sub>2</sub>, Nd:YAG)
- Laser welding/soldering system

**Autonics Corporation**  
http://www.autonics.com

**Satisfiable Partner For Factory Automation**

**HEAD QUARTERS :**  
41-5, Yongdang-dong, Yongsan-si, Gyeongnam, 626-847, Korea

**OVERSEAS SALES :**  
Bldg. 402 3rd FL., Bucheon Techno Park, 193, Yakdae-dong, Wornji-gu, Bucheon-si, Gyeonggi-do, 420-734, Korea  
TEL : 82-32-610-2730 / FAX : 82-32-329-0728  
E-mail : sales@autonics.com

**The proposal of a product improvement and development : product@autonics.com**